



1.	3
2.	4
2.1	4
2.2	4
2.3	5
2.4		

1.

LT986
LED

LT986 0.4ohm
LED
LED

2.

2.1

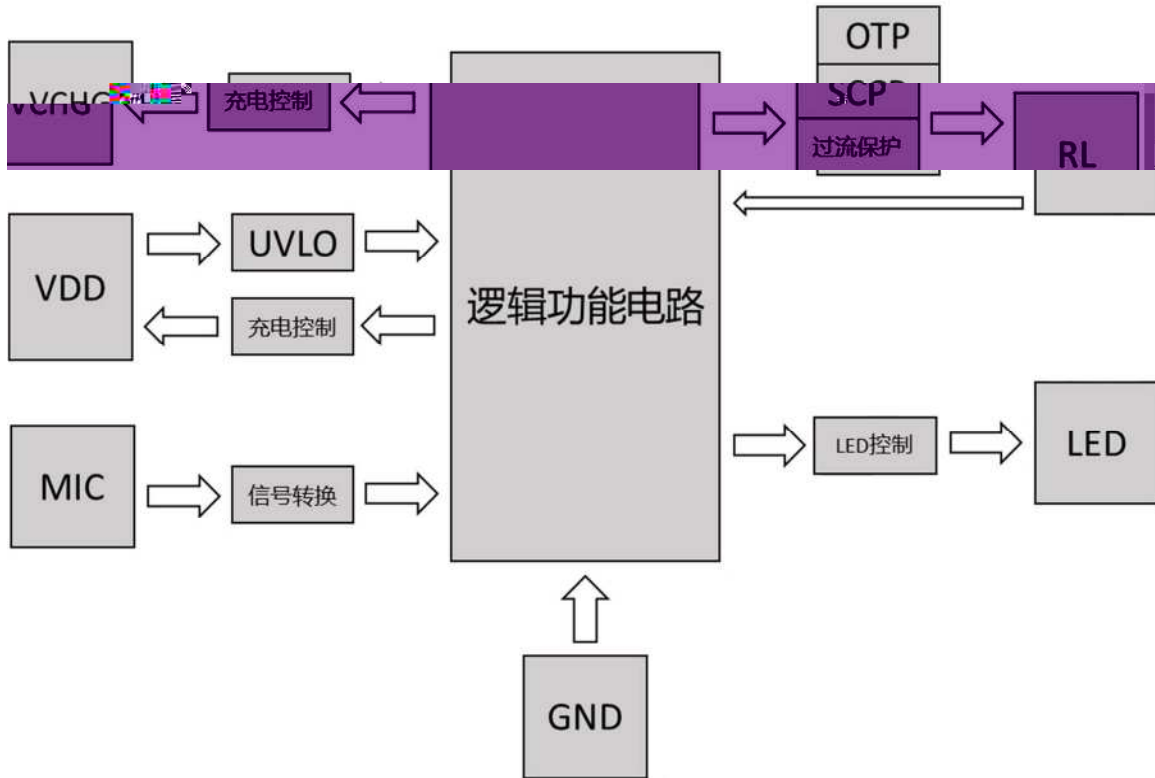

2.2

外形	序号	符号	功能描述
	1	VCHG	充电电源输入
	2	GND	地
	3	MIC	吸烟检测 (SENSOR)
	4	LED	接LED
	5	VOUT	接电热丝
	6	VDD	由电池正端

2.3

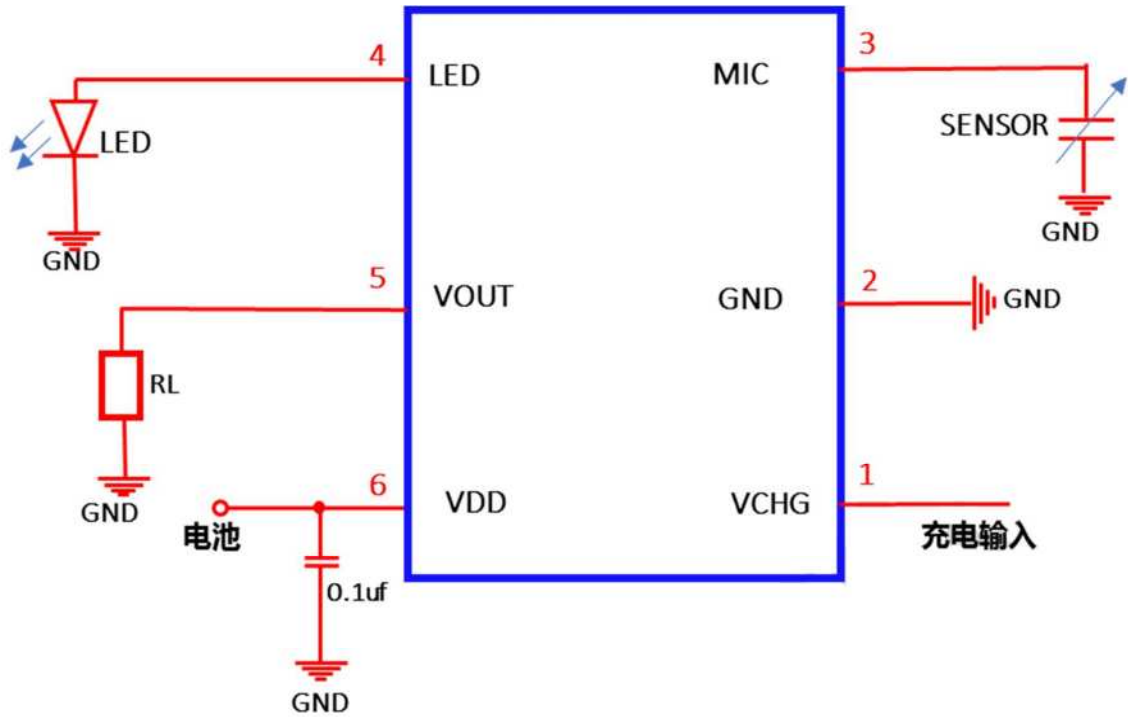

2.4

2.4.1

LED

2.4.2 LED

LED
LED

2.4.3

AC-DC USB

2.7V

2.7V

4.2V

4.2V

2.4.4

OSC

33KHz

2.4.5

UVLO

3.3V

UVLO

SCP

0.4 ohm

OTP

2.5 LED

	LED
	1
/	/
	2
	2
	3
	3



